

**Our associates will ensure the tool works properly before you leave the store. If you experience issues with the tool while completing your project, simply bring it back to the Tool Rental Center to get a replacement. If you purchase Damage Protection at the time of your rental, you are not responsible for repair costs for tools that break due to normal use.**



LSC1.4S

**LSC****Submersible Residue Dewatering Pump****LSP****Self-Priming Residue Dewatering Pump****OPERATION MANUAL****INTRODUCTION**

Thank you for selecting the Tsurumi LSC Submersible Residue Dewatering Pump and LSP Self-Priming Residue Dewatering Pump.

This equipment should not be used for applications other than those listed in this manual. Failure to observe this precaution may lead to a malfunction or an accident. In the event of a malfunction or an accident, the manufacturer will not assume any liability. After reading this Operation Manual, keep it in a location that is easily accessible, so that it can be referred to whenever information is needed while operating the equipment.

**CONTENTS**

1. BE SURE TO READ FOR YOUR SAFETY .....	1
2. PART NAMES.....	4
3. PRIOR TO OPERATION .....	5
4. INSTALLATION .....	6
5. ELECTRICAL WIRING .....	9
6. OPERATION.....	13
7. MAINTENANCE AND INSPECTION.....	14
8. DISASSEMBLY AND REASSEMBLY PROCEDURE .....	15
9. TROUBLESHOOTING .....	18



# 1 BE SURE TO READ FOR YOUR SAFETY

Be sure to thoroughly read and understand the SAFETY PRECAUTIONS given in this section before using the equipment in order to operate the equipment correctly.

The precautionary measures described in this section are intended to prevent danger or damage to you or to others. The contents of this manual that could possibly be performed improperly are classified into two categories: **⚠ WARNING**, and **⚠ CAUTION**. The categories indicate the extent of possible damage or the urgency of the precaution. Note however, that what is included under **⚠ CAUTION** may at times lead to a more serious problem. In either case, the categories pertain to safety-related items, and as such, must be observed carefully.

- **⚠ WARNING** : Operating the equipment improperly by failing to observe this precaution may possibly lead to death or injury to humans.
- **⚠ CAUTION** : Operating the equipment improperly by failing to observe this precaution may possibly cause injury to humans and other physical damage.
- **NOTE** : Gives information that does not fall in the WARNING or CAUTION categories.

## ● Explanation of Symbols:



-  : The  $\triangle$  mark indicates a WARNING or CAUTION item. The symbol inside the mark describes the precaution in more detail ("electrical shock", in the case of the example on the left).
-  : The  $\circ$  mark indicates a prohibited action. The symbol inside the mark, or a notation in the vicinity of the mark describes the precaution in more detail ("disassembly prohibited", in the case of the example on the left).
-  : The  $\bullet$  mark indicates an action that must be taken, or instructs how to perform a task. The symbol inside the mark describes the precaution in more detail ("provide ground work", in the case of the example on the left).

## PRECAUTIONS TO THE PRODUCT SPECIFICATIONS









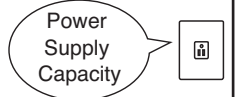



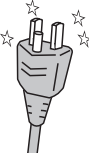

<b>⚠ CAUTION</b>	
	<ul style="list-style-type: none"> <li>● Do not operate the product under any conditions other than those for which it is specified. <b>Failure to observe the precaution can lead to electrical leakage, electrical shock, fire, or water leakage, etc.</b></li> </ul>























## PRECAUTIONS DURING TRANSPORT AND INSTALLATION

<b>⚠ WARNING</b>	
	<ul style="list-style-type: none"> <li>● When transporting the product, pay close attention to its center of gravity and mass. Use an appropriate lifting equipment to lift the unit. <b>Improper lifting may result in the product damage, injury, or death.</b></li> </ul>
	<ul style="list-style-type: none"> <li>● Electrical wiring should be performed in accordance with all applicable regulations in your country. Provide a dedicated earth leakage circuit breaker and a thermal overload relay for the pump. <b>Imperfect wiring or neglecting the installation of proper equipment will cause electrical leakage, fire, or explosion at worst.</b></li> </ul>
	<ul style="list-style-type: none"> <li>● Use a power outlet that has a sufficient rating and has been exclusively provided for the pump. <b>If the power outlet is shared with other equipment, it can lead to an abnormal heat of the outlet and can cause fire as a result.</b></li> </ul>







 <b>CAUTION</b>	
 <ul style="list-style-type: none"> <li>● Be sure to provide a ground wire securely. Do not connect the ground wire to a gas pipe, water pipe, lightning rod, or telephone ground wire. <b>Improper grounding could cause electrical shock.</b></li> </ul> 	 <ul style="list-style-type: none"> <li>● Prevent a metallic object or dust from sticking to the power plug. <b>Adhesion of foreign object to the plug could cause electrical shock, short-circuit, or fire.</b></li> </ul> 
 <ul style="list-style-type: none"> <li>● Do not scratch, fold, twist, make alterations, or bundle the cable, or use it as a lifting device. <b>The cable may be damaged, which may cause electrical leakage, short-circuit, electrical shock, or fire.</b></li> </ul> 	 <ul style="list-style-type: none"> <li>● Do not use the cable if it is damaged or it is not closely fitted. Connect every conductor of the cable securely to the terminals. <b>Failure to observe this can lead to electrical shock, short-circuit, or fire.</b></li> </ul> 
 <ul style="list-style-type: none"> <li>● This pump is neither dust-proof nor explosion-proof. Do not use it at a dusty place or at a place where toxic, corrosive or explosive gas is present. <b>Use in such places could cause fire or explosion.</b></li> </ul> 	 <ul style="list-style-type: none"> <li>● When transporting or installing the pump, bring it with the handle. When lifting the product, tie a rope to the handle tightly. <b>Transporting or lifting the pump with its cable may damage the cable, which may cause electrical leakage, electrical shock, or fire.</b></li> </ul> 
 <ul style="list-style-type: none"> <li>● If a hose is used for the discharge line, take a measure to prevent the hose from shaking. <b>If the hose shakes, you may be wet or injured.</b></li> </ul> 	



## PRECAUTIONS DURING TEST OPERATION AND OPERATION

 <b>WARNING</b>	
 <ul style="list-style-type: none"> <li>● Never start the pump while it is suspended, as <b>the unit may jerk and could lead to injury.</b></li> </ul> 	 <ul style="list-style-type: none"> <li>● When inspecting the pump, be sure to turn off the power supply (earth leakage circuit breaker, etc.) so that the pump may not start accidentally. <b>Failure to do so may lead to a serious accident.</b></li> </ul> 
 <b>CAUTION</b>	
 <ul style="list-style-type: none"> <li>● Do not operate the product under any voltage other than described on the nameplate with the voltage tolerance limit within <math>\pm 5\%</math>. If it is operated with a generator, it is strongly suggested not to operate other equipment with the same generator. <b>Failure to observe this caution may cause malfunction and breakdown of the product, which may lead to electrical leakage or electrical shock.</b></li> </ul> 	 <ul style="list-style-type: none"> <li>● Do not touch the product with bare hands during or immediate after the operation, as the product may become very hot during operation. <b>Failure to observe this caution may lead to burn. Especially, when opening the priming plug, pay attention to a phenomenon that hot water may spout from the pump.</b></li> </ul> 
 <ul style="list-style-type: none"> <li>● Do not use the product in a liquid other than water. <b>Use in oil, salt water or organic solvents will damage it, which may lead to electrical leakage or electrical shock.</b></li> </ul> 	 <ul style="list-style-type: none"> <li>● Do not run the product dry or operate it with its valve (sluice or gate valve) closed, as <b>doing so will damage the product, which may lead to electrical leakage or electrical shock.</b></li> </ul> 
 <ul style="list-style-type: none"> <li>● Do not use the product for hot or warm liquid over <math>40^{\circ}\text{C}</math>, as <b>doing so will damage the product, which may lead to electrical leakage or electrical shock.</b></li> </ul> 	 <ul style="list-style-type: none"> <li>● When operating the pump with its valve (sluice or gate valve) closed, it may become very hot. <b>Be careful not to contact the pump accidentally to avoid being burned.</b></li> </ul>
 <ul style="list-style-type: none"> <li>● Do not allow foreign objects (metal objects such as pins or wires) to enter the suction inlet of the pump. <b>Failure to observe this caution could cause it to malfunction or to operate abnormally, which may lead to electrical leakage or electrical shock.</b></li> </ul> 	 <ul style="list-style-type: none"> <li>● When the product will not be used for an extended period, be sure to turn off the power supply (earth leakage circuit breaker, etc.). <b>Deterioration of the insulation may lead to electrical leakage, electrical shock, or fire.</b></li> </ul> 

## PRECAUTIONS DURING MAINTENANCE AND INSPECTION

⚠ WARNING	
⊘	<p>● Absolutely turn off the power supply before starting maintenance or inspection, and perform the work after making sure that the impeller has stopped completely. Do not work with wet hands. <b>Failure to observe these cautions may lead to electrical shock or injury.</b></p> <p style="text-align: right;">OFF  STOP </p>
!	<p>● In case any abnormality (excessive vibration, unusual noise or odor) is found in the operation, turn the power off immediately and consult with the dealer where it was purchased or Tsurumi representative. <b>Continuing to operate the product under abnormal conditions may result in electrical shock, fire, or water leakage.</b></p> <p style="text-align: right;">OFF  </p>
⚠ CAUTION	
!	<p>● After reassembly, always perform a test operation before resuming use of the product. <b>Improper assembly can result in electrical leakage, electrical shock, fire, or water leakage.</b></p> <p style="text-align: right;">Test operation </p>

## PRECAUTION TO POWER OUTAGE

⚠ WARNING	
!	<p>● In case of power outage, turn off the power supply. <b>The product will resume operation when the power is restored, which presents serious danger to people in the vicinity.</b></p> <p style="text-align: right;">power outage  OFF </p>

## OTHER PRECAUTION

⚠ CAUTION	
⊘	<p>● Never use the product for potable water. <b>It may present a danger to human health.</b></p> <p style="text-align: right;"> Potable Water</p>

⚠ CAUTION	
⊘	<ul style="list-style-type: none"> <li>● This appliance is not intended for use by persons (including children) with reduced physical, sensory or mental capabilities, or lack of experience and knowledge, unless they have been given supervision or instruction concerning use of the appliance by a person responsible for their safety.</li> <li>● Children should be supervised to ensure that they do not play with the appliance.</li> <li>● If the supply cord is damaged, it must be replaced by the manufacturer, its service agent or similarly qualified persons in order to avoid a hazard.</li> <li>● Pollution of the liquid could occur due to leakage of lubricants.</li> <li>● The pump must be supplied through a residual current device (RCD) having a rated residual operating current not exceeding 30 mA.</li> </ul>

## 2 PART NAMES

### ■ LSC1.4S

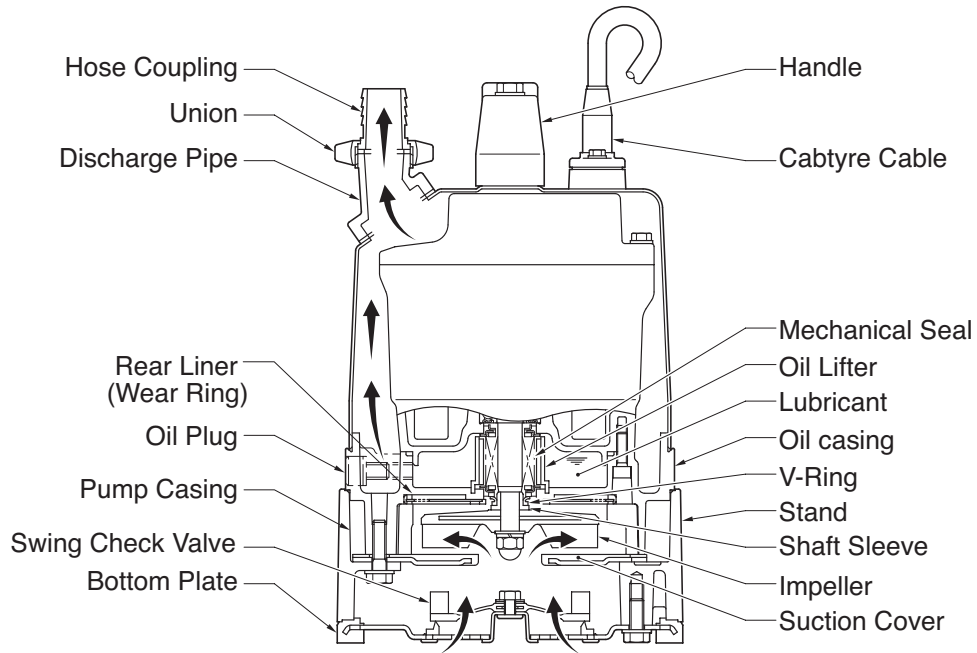

### ■ LSP1.4S

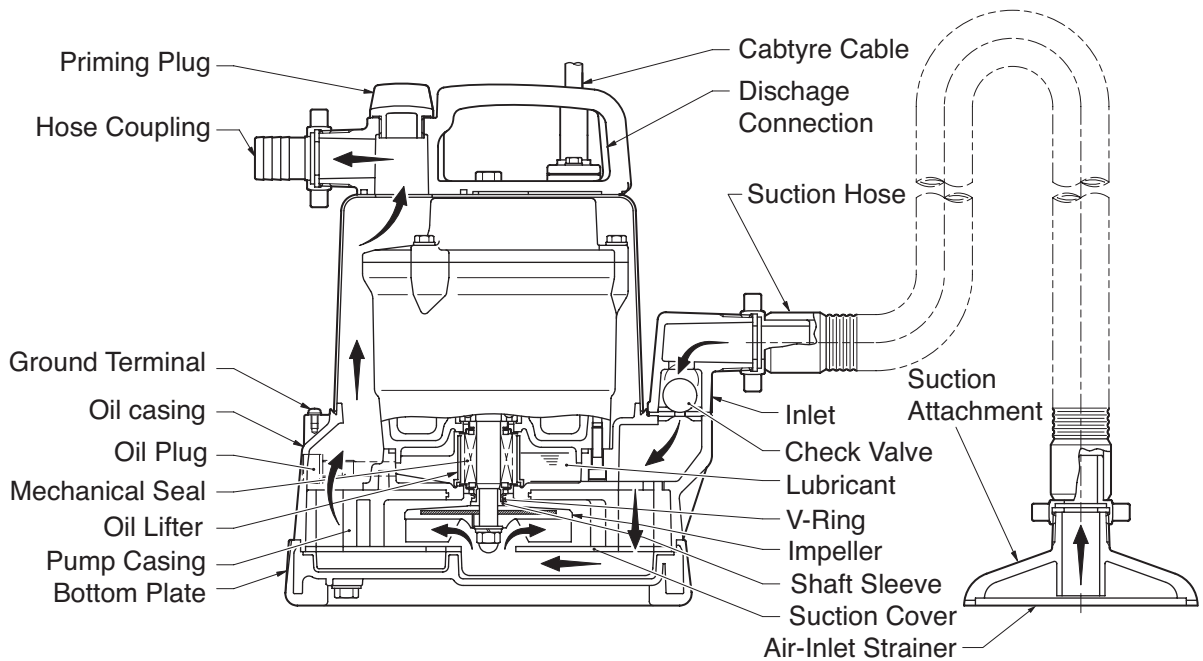

# 3 PRIOR TO OPERATION

When the pump is delivered, first perform the following checks.

## Product Inspection

While unpacking, inspect the product for damage during shipment, and make sure all bolts and nuts are tightened properly.

## Specification Check

Check the model number to make sure it is the product that was ordered. Be certain it is the correct voltage and frequency.

### Example of nameplate for LSC

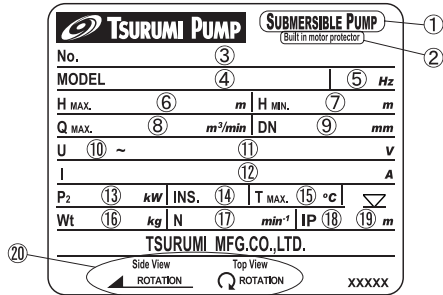

4		5 Hz		SUBMERSIBLE PUMP (Built in motor protector)		IP 18		(19) m	
DN 9	mm	P <sub>2</sub> 13	kW	U 10	~	(11)	V	I 12	A
H MAX. 6	m	N 17	min <sup>-1</sup>	INS. 14		T MAX. 15 °C		Wt 16 kg	
H MIN. 7	m	INS. 14		T MAX. 15 °C		IP 18		(19) m	
Wt 16 kg		T MAX. 15 °C		TSURUMI Mfg.Co.,Ltd.		XXXXX			

1	Submersible pump	11	Rated voltage
2	Built in motor protector	12	Rated current
3	Serial number	13	Rated output power
4	Model	14	Insulation class
5	Frequency	15	Max. liquid temperature
6	Max. total head	16	Weight without cable
7	Min. total head	17	Speed of rotation
8	Max. flow rate	18	IP degree of protection
9	Discharge bore	19	Max. immersion depth
10	Phase	20	Direction of rotation

### Example of nameplate for LSP

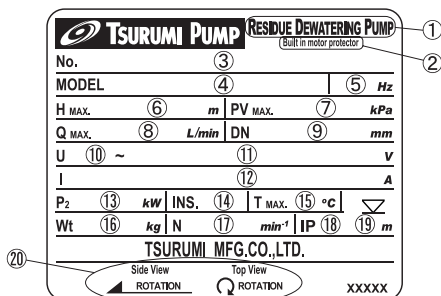

1	Residue dewatering pump	10	Phase
2	Built in motor protector	11	Rated voltage
3	Serial number	12	Rated current
4	Model	13	Rated output power
5	Frequency	14	Insulation class
6	Max. total head	15	Max. liquid temperature
7	Max. vacuum (negative pressure)	16	Weight without cable
		17	Speed of rotation
8	Max. flow rate	18	IP degree of protection
9	Suction bore	19	Max. immersion depth
	x Discharge bore	20	Direction of rotation

## Accessory Check

Verify that all accessory items are included in the package.

### LSC Type

- Hose Band ..... 1 pc
- ø25mm Hose Coupling with Union Hose Band ..... 1 set } Models for US are excluded
- Operation Manual ..... 1

### LSP Type

- ø25mm Hose Coupling with Union Hose Band ..... 1 set
- Suction Hose with Union (5m) ..... 1 set
- Suction Attachment ..... 1 set
- Operation Manual ..... 1

**Note:** If there is any problem with the product as shipped, contact your nearest dealer or Tsurumi representative at once.

## Product Specifications

**CAUTION** Do not operate this product under any conditions other than those for which it is specified. Failure to observe this precaution can lead to electrical shock, electrical leakage, fire, water leakage or other problems.

### Major Standard Specifications

Fluid	Property	Cleaning Water, Water on floor Puddles (LSC1.4S). Residual water, Puddles (LSP1.4S) ; 0 ~ 40°C
Pump	Impeller	Semi-Vortex Type
	Shaft Seal	Double Mechanical Seal
	Bearing	Shielded Ball Bearing
Motor	Specifications	Dry Type Submersible Induction Motor (2-Pole)
	Insulation	Class E
	Protection System (built-in)	Miniature Protector
	Lubricant	Turbine Oil ISO VG32 (non-additive)
Discharge Connection		Hose Coupling

### Standard Specifications (50/60 Hz)

Model	Bore (mm)	Phase	Starting Method	Output kW (HP)	Max. Head m(ft.)	Max. Capacity L/min(GPM)	Weight kg (lbs.)
LSC1.4S	25	Single	Capacitor Run	0.48 (2/3)	11/12(36/39)	—	12.0 (26.5)
LSCE1.4S	25	Single	Capacitor Run	0.48 (2/3)	11/12(36/39)	—	12.6 (27.8)
LSP1.4S	25	Single	Capacitor Run	0.48 (2/3)	6.9/7.8(22.6/25.6)	50/55(13.2/14.5)	16.5 (36.4)

**Note:** The mass (weight) given above is the dry weight of the pump itself, not including the cable.

## 4 INSTALLATION

**CAUTION**

- Do not use the pump in liquids other than plain water, such as oil, salt water, or organic solvents.
- Use with a power supply voltage within  $\pm 5\%$  of the rated voltage.
- Do not use in the water temperatures outside the range of 0 ~ 40°C, which can lead to failure, electrical leakage or shock.
- Do not use in the vicinity of explosive or flammable materials.
- Use only in fully assembled state.

**Note:** Consult your local dealer or Tsurumi representative before using with any liquids other than those indicated in this document.

### Maximum allowable water pressure

**CAUTION** Do not use at greater than the water pressure shown below.

Maximum allowable water pressure : 0.2MPa (2kgf/cm<sup>2</sup>) - discharge pressure during use

### Preparation for Installation

Before installing the pump at a work site, you will need to have the following tools and instruments ready.

- AC voltmeter
- AC ammeter (clamp-on type)
- Bolt and nut tighteners
- Power supply connection tools (screwdriver or box wrench)

**Note:** Please read also the instructions that come with each of the test instruments.

- (2) Avoid dropping the pump or other strong impact. Lift the pump by holding it firmly with the hands or by attaching a rope or chain to the handle.

 **CAUTION** The rope for suspending the pump during its installation must be of a thickness that accommodates the weight of the pump. When using a chain, make sure that the chain does not become twisted. Failure to observe these precautions could cause the rope or chain to break and the pump to fall and break, which could lead to personal injury.

**Note:** *On cable handling, see at electrical Wiring.*

 **CAUTION** Operating the pump when the inlet is blocked with debris will result in excessive noise and vibration, which can cause the pump to malfunction, leading to electrical leakage and shock.

**Note:** *This pump is supplied without piping. Use it with suitable piping material.*

*When used with a hose, pay attention to the following precautions.*

*Make sure the hose has no sharp bends, which can severely limit the flow of water. In particular, sharp bends near the base may cause air pockets to form resulting in idle operation. Lessen the degree of bedding while continuing to operate the pump. The tip of the hose (discharge end) should be located higher than the water surface. If the end of the hose is submerged, water may flow back to the pump when the pump is stopped; and if the hose end is lower than the water surface, water may overflow when the pump is turned off.*

 **CAUTION** If large quantities of earth are sucked up, damage resulting from abrasion in the pump can lead to electrical leakage and shock.

- (3) Use the pump in the upright position and on a flat surface. If the pump is likely to suck up sand or debris, mount it in a protective box or enclose it with a screen.

**Note:** *In the case of the LSP, installing the pump on an incline will alter the available circulation water capacity, lowering pump performance or even resulting in a total loss of suction.*

## Operation Water Level (LSCE1.4S)

### Start of the pump

The pump starts when the current continuously flows between the two electrodes for more than one(1) second.

**Note:** *The electrode may not detect the watersurface under conditions such as purified water or distilled water which the current does not flow cause of high specific resistance.*

**Note:** *The necessary water level to operate the pump is 85 mm from the bottom of a pump.  
In case of start by racing during the trial operation, please short-circuit for more than one (1) second with exciting items (screw driver etc.) between the electrodes, and start forcibly.  
Please keep away from those that may clog in a pump. (wire, nail, cord, etc.)*

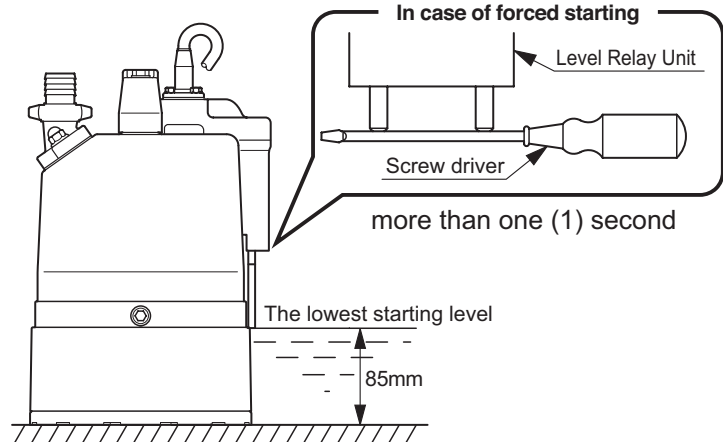

### Trial Operation

**⚠ WARNING** Never start the pump while it is suspended, as the pump may jerk and cause a serious accident involving injury.

(1) Operate the pump 3 to 10 minutes to verify the conditions listed below.

**⚠ CAUTION** If large quantities of earth are sucked up, damage resulting from abrasion in the pump can lead to electrical leakage and shock.

(2) Proceed with the normal operation if no abnormal conditions are found during the trial operation.

## Operation Water Level (LSCE1.4S)

To enable the user to bring the pumps ability into full play, this chart describes the various control modes that are made possible by the combinations of the electrode and timer functions.

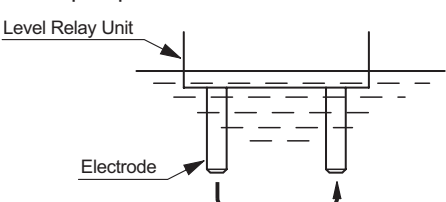
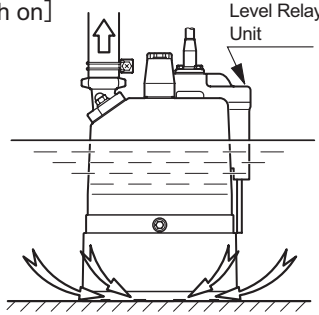
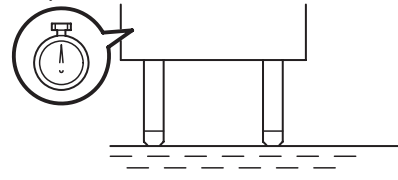
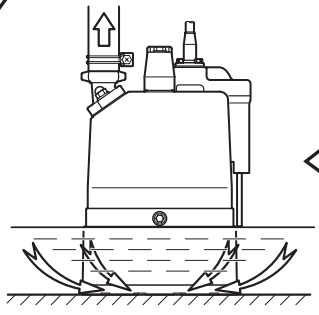
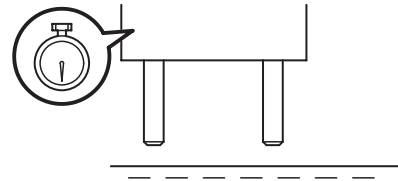
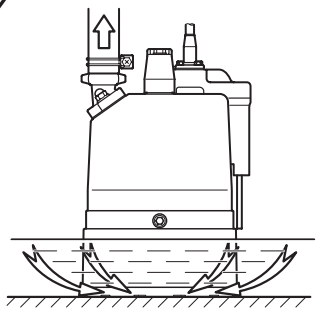
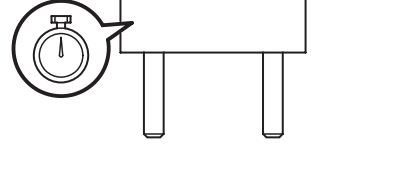
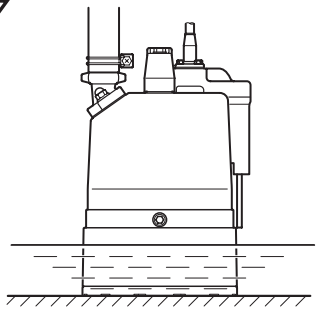
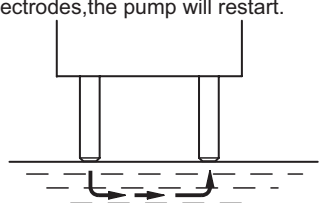
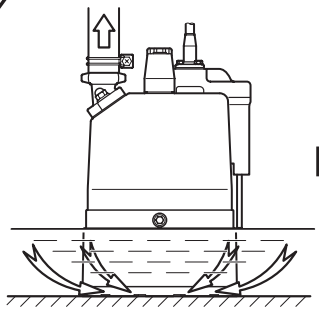
Level Relay Unit	Pump	Water Level	Condition
<p>The electrodes of the level relay unit are submerged, causing the current to operate the pump.</p>  <p>(Detection Time : more than one (1) second)</p>	Start Operation (Drainage)	Drop	<p>[Swich on]</p> 
<p>As the water level drops and the water surface recedes from the electrodes, the timer trips to drain water.</p>  <p>(Electrodes open Trips the timer)</p>	Operation (Drainage)	Drop	
<p>The draining of water by the timer lasts approxiamter 1 minute.</p> <p>※If the water surface comes in contact for more than one (1) second with the electrodes witin 1 minute, the pump will operate continuously even though the timer has tripped.</p> 	Operation (Drainage)	Drop	
<p>The pump will stop 1 minute later.</p>  <p>※The pump will also stop after a continuous dry run, in some cases.</p>	Stop	Rise	
<p>When the water level rises and the water surface comes in contact for more than one (1) second with the electrodes, the pump will restart.</p>  <p>(Detection Time : more than one (1) second)</p>	Start Operation (Drainage)	Drop	

## 6 OPERATION

### Before starting

- (1) Make sure once again that the product is of the correct voltage and frequency rating.

**CAUTION** Using the product at other than rated voltage and frequency will not only lower its performance but may damage the product.

**Note:** Confirm the rated voltage and frequency on the model name plate.

- (2) Confirm the wiring, supply voltage, circuit breaker capacity, and motor insulation resistance.

■ Reference insulation resistance = 20MΩ or greater.

**Note:** The reference insulation resistance (20MΩ or greater) is the value when the pump is new or has been repaired. For the reference value after installation, see below at Maintenance and Inspection (p. 11).

- (3) The setting on the circuit breaker or other overload protector should be made in accord with the rated current of the pump.

**Note:** See the model name plate on the pump for its rated current.

- (4) When powering the pump with a generator, do not share the generator with other equipment.

### Test Operation

**WARNING** Never Operate the pump while it is suspended in the air. The recoil may result in injury or other major accident.  
Never start the pump when people are standing next to it. An electrical leak can result in electrical shock.

- (1) •Model LSC

The Pump will not start until the pump casing is wet. When doing a test operation or if it is desired to start the pump when the remaining water level is low, pour in clean water from the hose coupling. Approximately 2.5 liter of priming water is required.

- Model LSP

Remove the priming plug at the top of the pump and pour in clean water right up to the top: then replace the priming plug and tighten it. Approximately 1.8 liter of priming water is required.

- (2) Run the pump for a short time (3 to 10 minutes) and check its operation.

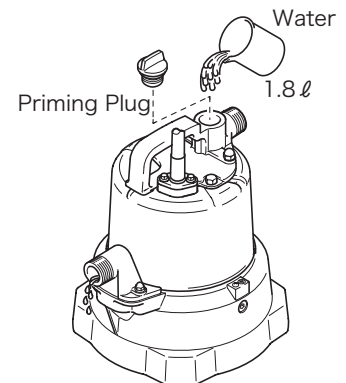

**CAUTION** Do not run the pump dry or with shut off condition. This condition may damage the pump or cause it to malfunction and may result in electrical leakage or electrical shock.

**CAUTION** In case of very excessive vibration, unusual noise or odor, turn off the power immediately and consult with your nearest dealer or Tsurumi representative. Continuing to operate the pump under abnormal conditions may result in electrical shock, fire, or electrical leakage.

### Operation

**WARNING** The pump may become very hot during operation. Be careful not to contact the pump accidentally to avoid being burned.

Always make sure the pump is primed before starting operation.

If the motor protection system operates due to an overload or malfunction, causing the pump to stop, first investigate and remove the cause before restarting.

If LSC is used: After stopping operation, detach the hose from the discharge connector and turn the pump upside-down to remove the water inside the pump.

# 7 MAINTENANCE AND INSPECTION

Regular maintenance and inspections are a necessity for continued efficient functioning of the pump. If any abnormal conditions are noticed, refer to the section on troubleshooting (P.15) and take corrective measures immediately. It is recommended that a spare pump be kept ready in case of any problems.

## Prior to Inspecting

**WARNING** Detach the cabtyre cable from the receptacle or terminals, after making certain the power supply (circuit breaker, etc.) is turned off. Failure to follow this precaution may result in a serious accident from electrical shock or unexpected starting of the pump motor.

- (1) Washing the Pump  
Remove accumulated matter from the surface of the pump and wash it with clean water. Take special care to remove any debris from the impeller.
- (2) Inspecting the Pump Exterior  
Look for any peeling or chipped paint, and make sure the nuts and bolts are fastened tightly. Any cracks in the surface should be repaired by cleaning that area, drying it and then applying a touchup coating.

**Note:** *Touchup is not supplied. Note that some kinds of damage or looseness may require that the unit be disassembled for repairs. Please consult with your nearest dealer or Tsurumi representative.*

## Regular Inspection

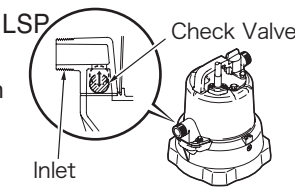
Frequency	Inspection Items
Weekly	Measure insulation resistance ■Reference insulation resistance = 1MΩ minimum <b>NOTE:</b> <i>If the insulation resistance has become notable lower than the previous inspection, an inspection of the motor will be necessary.</i> Measure operating current. ■Compare with rated current Measure supply voltage ■Power supply voltage tolerance ( within ±5% of the rated voltage)
Monthly	Pump Inspection. ■ A noticeable drop in performance may indicate wear in the impeller, suction cover, etc., or else clogging of the impeller, etc. Remove the clogged debris, and replace any worn parts. Swing check valve inspection (LSC). ■ If the lip on the bottom plate becomes excessively rounded off, or if the rubber material of the swing check valve is deteriorated, shutoff function of the valve decrease. Replace the bottom plate and/or the swing check valve. Check valve inspection (LSP). ■ The check valve may fail to operate if sand or debris at attached to it. Wash the valve and inside the inlet at regular intervals. The check valve can be removed by removing the inlet hex.bolt. <b>NOTE:</b> <i>In some case a siphon effect when the pump stops can cause water to reverse its flow or the priming water to flow out.</i> <div style="float: right; text-align: center;">  </div>
Half-yearly	Oil inspection. ■Every 1,000 hours of operation or six months, whichever comes first. Inspection of lifting rope or chain ■ Replace if damage, corrosion, or wear has occurred to the rope or the chain. Remove if foreign object is attaching to it.
yearly	Changing oil. ■Every 2,000 hours of operation or 12 months, whichever comes first. Designated oil: Turbine Oil ISO VG32. Oil Quantity: 155ml (LSC) ; 150ml (LSP) <b>NOTE:</b> <i>See below on OIL inspection and oil change.</i>
Every 2 to 5 years	Change mechanical seal. <b>NOTE:</b> <i>Specialized know-how is required for inspecting and replacing the mechanical seal. Consult with your nearest dealer or Tsurumi representative.</i> Overhaul ■ This should be carried out even if there are no problems with the pump. The frequency depends on how continuously the pump is in use. <b>NOTE:</b> <i>Consult with your nearest dealer or Tsurumi representative regarding overhauls.</i>

## 9 TROUBLESHOOTING

**⚠ WARNING** Always turn off the power before inspecting the pump. Failure to observe this precaution can result in serious accident.

Before ordering repairs, carefully read through this instruction manual, then repeat the inspection. If the problem remains, contact your nearest dealer or Tsurumi representative.

### ■ LSC

Problem	Possible cause	Countermeasure
Pump fails to start; or, starts but stops immediately (within 10 seconds).	(1)(No proper power is supplied (power outage, etc.) (2)Pump is jammed with debris, causing the motor protector to trip.	(1>Contact the electric power company or an electrical repair shop to take action. (2)Inspect the pump unit and remove the debris.
During operation, the pump stops automatically due to the tripping of the motor protector.	(1)The pump casing is filled with mud. (2)The voltage is too low. (3)The pump was operated dry for a prolonged length of time as a result of the clogging of the suction strainer of the bottom plate. It pumps too much mud. (4)A 50Hz pump is operated at 60Hz.	(1)Disassemble and clean the pump. Detach the suction cover, remove the mud, and manually turn the pump. (2)Raise the voltage to the rated voltage. (3)Remove debris. (4)Check the nameplate and replace the pump.
The pumping head and volume are small.	(1)The impeller or the suction cover is significantly worn. (2)The drain hose is kinked or clogged. (3)The suction strainer of the bottom plate is clogged. (4)The suction inlet is clogged with debris. (5)A 50Hz pump is operated at 60Hz.	(1)Repair or replace the affected part. (2)Straighten the curved or kinked part as much as possible. (3)Remove debris. (4)Remove the bottom plate to remove the debris from the inside of the suction inlet. (5)Check the nameplate and replace the pump.
Does not draw water at low water level.	(1)There is no water in the pump.	(1)Prime the pump.
After the pump stops, the priming water flows out.	(1)The swing check valve and/or the lip on the bottom plate is worn.	(1)Replace the swing check valve and/or the bottom plate.

### ■ LSP

Problem	Possible cause	Countermeasure
Pump fails to start; or, starts but stops immediately (within 10 seconds).	(1)No proper power is supplied (power outage, etc.) (2)Pump is jammed with debris, causing the motor protector to trip.	(1>Contact the electric power company or an electrical repair shop to take action. (2)Inspect the pump unit and remove the debris.
Pump operates but does not draw water.	(1)There is no priming water or is insufficient. (2)The bottom plate is installed incorrectly. (3)The suction hose or the sweeper suction attachment is not securely connected.	(1)Pour fresh water (approximately 1.8L). (2)Re-install the bottom plate with its arrow facing the suction inlet. (3)Connect it securely.
The pump stops after operating for a predetermined length of time.	(1)The voltage is too low. (2)A 50Hz pump is operated at 60Hz.	(1)Raise the voltage to the rated voltage. (2)Check the nameplate and replace the pump.
The pumping head and volume are small. Its suction performance is poor.	(1)The impeller or the suction cover is significantly worn. (2)The drain hose is kinked or clogged. (3)The suction hose or the sweeper suction attachment is clogged or submerged in sand. (4)The suction inlet is clogged with debris. (5)A 50Hz pump is operated at 60Hz.	(1)Repair or replace the affected part. (2)Straighten the curved or kinked part as much as possible. (3)Clean the suction hose and the suction attachment. (4)Remove the suction inlet to clean the suction inlet and the check valve. (5)Check the nameplate and replace the pump.
Pump vibrates or makes abnormal sounds.	(1)The motor bearings are damaged.	(1)Replace the bearings.
After the pump stops, the priming water flows out.	(1)The check valve does not function properly because it is stuck with mud.	(1)Clean the check valve and the inside of the suction inlet.

Our associates will ensure the tool works properly before you leave the store. If you experience issues with the tool while completing your project, simply bring it back to the Tool Rental Center to get a replacement. If you purchase Damage Protection at the time of your rental, you are not responsible for repair costs for tools that break due to normal use.





PXL-65011

## Submersible Pump

$\frac{3}{4}$ , 2 in Finishing Submersible

$\frac{1}{2}$  hp 110v Motor

Max Output 1500 gph

Max Head 36 ft

Model: PXL-65011

Category: Submersible Pumps

Applications: Agricultural, Construction, Municipal / Industrial

### Description

## Overview

### Outstanding Features

- Thermal Protected Motors
- Fits Into Small Diameter Holes
- Lightweight, Compact, and Easy to Carry.
- Completely Rebuildable Pumps
- Non-Toxic DTE 24 Light Paraffin Oil
- Single Piece Molded Power Cords Ensures a Water Tight Seal
- Oil Bathed Double Silicon Carbide Mechanical Seals, Allows for Periods of Dry Run
- Optional Float Switches Available for All Models (PB-68011 must be wired for 220v to utilize FS-30 Float

### PXL Family Description

Rubber Pump End, For Finishing, Removes Residual Water Left by Other Pumps, Pumps Down to 1mm, Anti-Backflow Check Valve, Outlet Can be Turned to Pump Horizontally. Perfect for Pool Covers, Man Holes, Bottom Pits, Pools, Basements, and Construction Sites

- Switch)
- Three Year Limited Warranty

# Specifications

Our specification are guaranteed minimum!

## Product Data

<b>Discharge Size</b>	<b>3/4" - 2" NPT</b>
<b>Maximum Output</b>	25 GMP
<b>Maximum Discharge Head</b>	36 ft.
<b>Voltage</b>	110
<b>Rated Current</b>	6.4 Amp
<b>Motor Output</b>	1/2 HP
<b>Cable Length</b>	20 ft.
<b>Package Weight</b>	26 lbs.
<b>Packaged Dimensions (LxWxH)</b>	8" x 8" x 13"

## PERFORMANCE CURVES

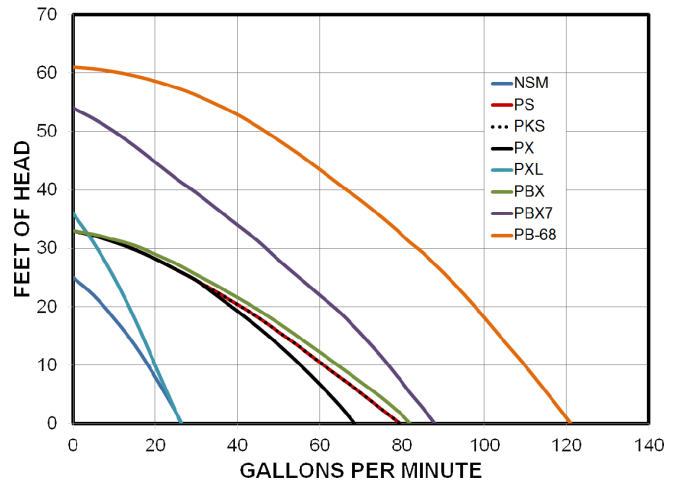

[DOWNLOAD PDF SPEC SHEET](#)



# 1 BE SURE TO READ FOR YOUR SAFETY

Be sure to thoroughly read and understand the SAFETY PRECAUTIONS given in this section before using the equipment in order to operate the equipment correctly.

The precautionary measures described in this section are intended to prevent danger or damage to you or to others. The contents of this manual that could possibly be performed improperly are classified into two categories: **⚠ WARNING**, and **⚠ CAUTION**. The categories indicate the extent of possible damage or the urgency of the precaution. Note however, that what is included under **⚠ CAUTION** may at times lead to a more serious problem. In either case, the categories pertain to safety-related items, and as such, must be observed carefully.

- **⚠ WARNING** : Operating the equipment improperly by failing to observe this precaution may possibly lead to death or injury to humans.
- **⚠ CAUTION** : Operating the equipment improperly by failing to observe this precaution may possibly cause injury to humans and other physical damage.
- **NOTE** : Gives information that does not fall in the WARNING or CAUTION categories.

## ● Explanation of Symbols:













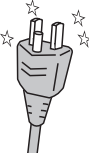

-  : The  $\triangle$  mark indicates a WARNING or CAUTION item. The symbol inside the mark describes the precaution in more detail ("electrical shock", in the case of the example on the left).
-  : The  $\circ$  mark indicates a prohibited action. The symbol inside the mark, or a notation in the vicinity of the mark describes the precaution in more detail ("disassembly prohibited", in the case of the example on the left).
-  : The  $\bullet$  mark indicates an action that must be taken, or instructs how to perform a task. The symbol inside the mark describes the precaution in more detail ("provide ground work", in the case of the example on the left).

## PRECAUTIONS TO THE PRODUCT SPECIFICATIONS





















<b>⚠ CAUTION</b>	
	<ul style="list-style-type: none"> <li>● Do not operate the product under any conditions other than those for which it is specified. <b>Failure to observe the precaution can lead to electrical leakage, electrical shock, fire, or water leakage, etc.</b></li> </ul>

## PRECAUTIONS DURING TRANSPORT AND INSTALLATION











<b>⚠ WARNING</b>	
<ul style="list-style-type: none"> <li>● When transporting the product, pay close attention to its center of gravity and mass. Use an appropriate lifting equipment to lift the unit. <b>Improper lifting may result in the product damage, injury, or death.</b></li> </ul>	<ul style="list-style-type: none"> <li>● Install the product properly in accordance with this instruction manual. <b>Improper installation may result in electrical leakage, electrical shock, fire, water leakage, or injury.</b></li> </ul>
<ul style="list-style-type: none"> <li>● Electrical wiring should be performed in accordance with all applicable regulations in your country. Provide a dedicated earth leakage circuit breaker and a thermal overload relay for the pump. <b>Imperfect wiring or neglecting the installation of proper equipment will cause electrical leakage, fire, or explosion at worst.</b></li> </ul>	<ul style="list-style-type: none"> <li>● Provide a secure grounding dedicated for the product. Never fail to provide an earth leakage circuit breaker and a thermal overload relay in your starter or control panel (Both available on the market). <b>If an electrical leakage occurs due to a product failure, it may cause electrical shock.</b></li> </ul>
<ul style="list-style-type: none"> <li>● Use a power outlet that has a sufficient rating and has been exclusively provided for the pump. <b>If the power outlet is shared with other equipment, it can lead to an abnormal heat of the outlet and can cause fire as a result.</b></li> </ul>	

 <b>CAUTION</b>	
 <ul style="list-style-type: none"> <li>● Be sure to provide a ground wire securely. Do not connect the ground wire to a gas pipe, water pipe, lightning rod, or telephone ground wire. <b>Improper grounding could cause electrical shock.</b></li> </ul> 	 <ul style="list-style-type: none"> <li>● Prevent a metallic object or dust from sticking to the power plug. <b>Adhesion of foreign object to the plug could cause electrical shock, short-circuit, or fire.</b></li> </ul> 
 <ul style="list-style-type: none"> <li>● Do not scratch, fold, twist, make alterations, or bundle the cable, or use it as a lifting device. <b>The cable may be damaged, which may cause electrical leakage, short-circuit, electrical shock, or fire.</b></li> </ul> 	 <ul style="list-style-type: none"> <li>● Do not use the cable, power plug, or power outlet if it is damaged or it is not closely fitted. Connect every conductor of the cable securely to the terminals. <b>Failure to observe this can lead to electrical shock, short-circuit, or fire.</b></li> </ul> 
 <ul style="list-style-type: none"> <li>● This pump is neither dust-proof nor explosion-proof. Do not use it at a dusty place or at a place where toxic, corrosive or explosive gas is present. <b>Use in such places could cause fire or explosion.</b></li> </ul> 	 <ul style="list-style-type: none"> <li>● When transporting or installing the pump, bring it with the handle. When lifting the product, tie a rope to the handle tightly. <b>Transporting or lifting the pump with its cable may damage the cable, which may cause electrical leakage, electrical shock, or fire.</b></li> </ul> 
 <ul style="list-style-type: none"> <li>● If a hose is used for the discharge line, take a measure to prevent the hose from shaking. <b>If the hose shakes, you may be wet or injured.</b></li> </ul> 	





## PRECAUTIONS DURING TEST OPERATION AND OPERATION

 <b>WARNING</b>	
 <ul style="list-style-type: none"> <li>● Never start the pump while it is suspended, as <b>the unit may jerk and could lead to injury.</b></li> </ul> 	 <ul style="list-style-type: none"> <li>● When inspecting the pump, be sure to turn off the power supply (earth leakage circuit breaker, etc.) so that the pump may not start accidentally. <b>Failure to do so may lead to a serious accident.</b></li> </ul> 
 <b>CAUTION</b>	
 <ul style="list-style-type: none"> <li>● Do not operate the product under any voltage other than described on the nameplate with the voltage tolerance limit within <math>\pm 5\%</math>. If it is operated with a generator, it is strongly suggested not to operate other equipment with the same generator. <b>Failure to observe this caution may cause malfunction and breakdown of the product, which may lead to electrical leakage or electrical shock.</b></li> </ul> 	 <ul style="list-style-type: none"> <li>● Do not touch the product with bare hands during or immediate after the operation, as the product may become very hot during operation. <b>Failure to observe this caution may lead to burn. Especially, when opening the priming plug, pay attention to a phenomenon that hot water may spout from the pump.</b></li> </ul> 
 <ul style="list-style-type: none"> <li>● Do not use the product in a liquid other than water. <b>Use in oil, salt water or organic solvents will damage it, which may lead to electrical leakage or electrical shock.</b></li> </ul> 	 <ul style="list-style-type: none"> <li>● Do not run the product dry or operate it with its valve (sluice or gate valve) closed, as <b>doing so will damage the product, which may lead to electrical leakage or electrical shock.</b></li> </ul> 
 <ul style="list-style-type: none"> <li>● Do not use the product for hot or warm liquid over <math>40^{\circ}\text{C}</math>, as <b>doing so will damage the product, which may lead to electrical leakage or electrical shock.</b></li> </ul> 	 <ul style="list-style-type: none"> <li>● When operating the pump with its valve (sluice or gate valve) closed, it may become very hot. <b>Be careful not to contact the pump accidentally to avoid being burned.</b></li> </ul>
 <ul style="list-style-type: none"> <li>● Do not allow foreign objects (metal objects such as pins or wires) to enter the suction inlet of the pump. <b>Failure to observe this caution could cause it to malfunction or to operate abnormally, which may lead to electrical leakage or electrical shock.</b></li> </ul> 	 <ul style="list-style-type: none"> <li>● When the product will not be used for an extended period, be sure to turn off the power supply (earth leakage circuit breaker, etc.). <b>Deterioration of the insulation may lead to electrical leakage, electrical shock, or fire.</b></li> </ul> 



## PRECAUTIONS DURING MAINTENANCE AND INSPECTION



 <b>WARNING</b>	
	<p>● Absolutely turn off the power supply before starting maintenance or inspection, and perform the work after making sure that the impeller has stopped completely. Do not work with wet hands. <b>Failure to observe these cautions may lead to electrical shock or injury.</b></p> <p style="text-align: right;">OFF  STOP </p>
	<p>● In case any abnormality (excessive vibration, unusual noise or odor) is found in the operation, turn the power off immediately and consult with the dealer where it was purchased or Tsurumi representative. <b>Continuing to operate the product under abnormal conditions may result in electrical shock, fire, or water leakage.</b></p> <p style="text-align: right;">OFF  </p>
 <b>CAUTION</b>	
	<p>● After reassembly, always perform a test operation before resuming use of the product. <b>Improper assembly can result in electrical leakage, electrical shock, fire, or water leakage.</b></p> <p style="text-align: right;">Test operation </p>

## PRECAUTION TO POWER OUTAGE

 <b>WARNING</b>	
	<p>● In case of power outage, turn off the power supply. <b>The product will resume operation when the power is restored, which presents serious danger to people in the vicinity.</b></p> <p style="text-align: right;">power outage  OFF </p>

## OTHER PRECAUTION

 <b>CAUTION</b>	
	<p>● Never use the product for potable water. <b>It may present a danger to human health.</b></p> <p style="text-align: right;"> Potable Water</p>

 <b>CAUTION</b>	
	<ul style="list-style-type: none"> <li>● This appliance is not intended for use by persons (including children) with reduced physical, sensory or mental capabilities, or lack of experience and knowledge, unless they have been given supervision or instruction concerning use of the appliance by a person responsible for their safety.</li> <li>● Children should be supervised to ensure that they do not play with the appliance.</li> <li>● If the supply cord is damaged, it must be replaced by the manufacturer, its service agent or similarly qualified persons in order to avoid a hazard.</li> <li>● Pollution of the liquid could occur due to leakage of lubricants.</li> <li>● The pump must be supplied through a residual current device (RCD) having a rated residual operating current not exceeding 30 mA.</li> </ul>

## 2 PART NAMES

### LSC1.4S

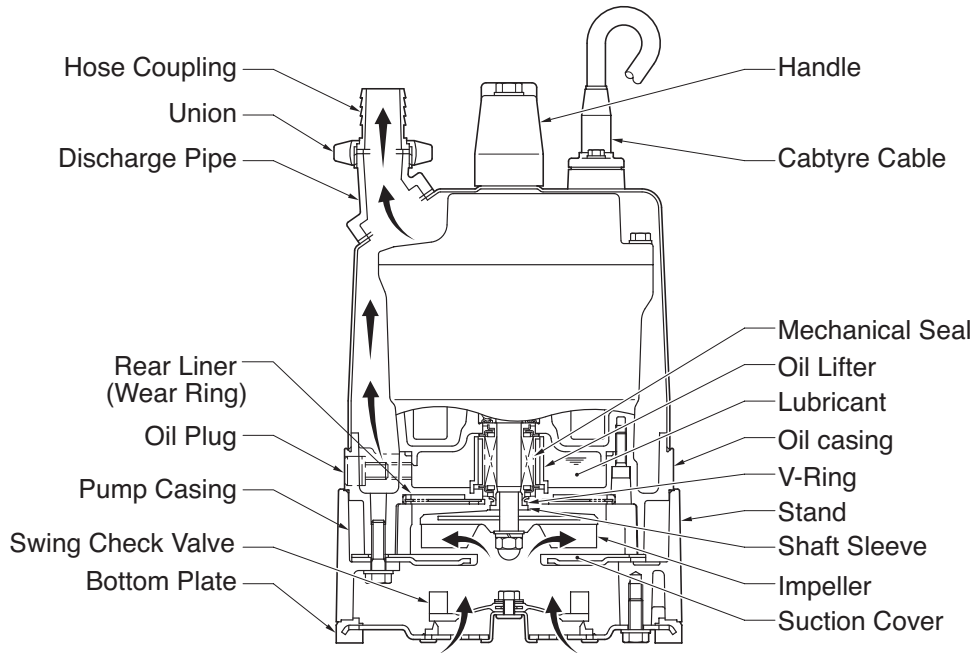

### LSP1.4S

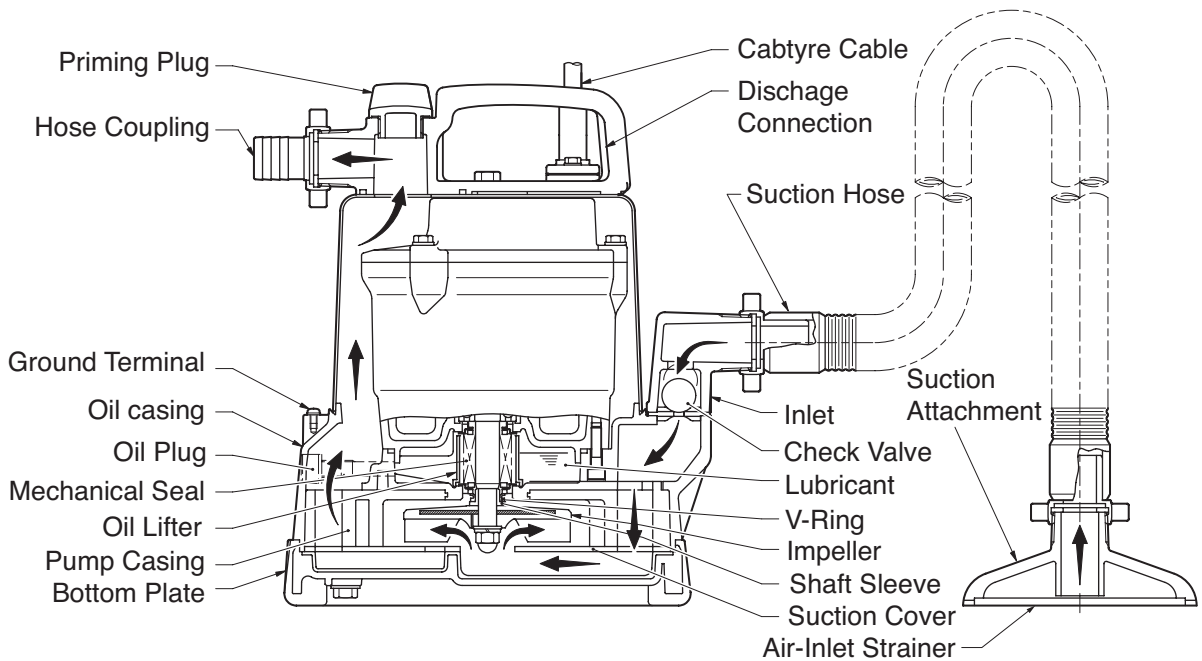

# 3 PRIOR TO OPERATION

When the pump is delivered, first perform the following checks.

## Product Inspection

While unpacking, inspect the product for damage during shipment, and make sure all bolts and nuts are tightened properly.

## Specification Check

Check the model number to make sure it is the product that was ordered. Be certain it is the correct voltage and frequency.

### Example of nameplate for LSC

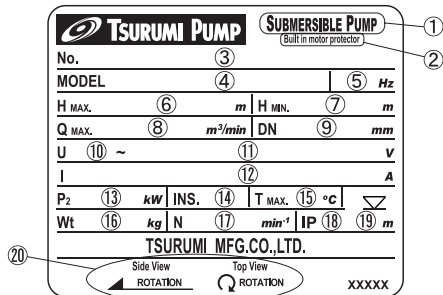

④	⑤ Hz	SUBMERSIBLE PUMP (Built in motor protector)	IP ⑱ ⑲ m
DN ⑨ mm	P <sub>2</sub> ⑬ kW	U ⑩ ~ ⑪ V	I ⑫ A
H MAX. ⑥ m	N ⑰ min <sup>-1</sup>	TSURUMI Mfg.Co.,Ltd.	
H MIN. ⑦ m	INS. ⑭	XXXXX	
Wt ⑯ kg	T MAX. ⑮ °C		

1	Submersible pump	11	Rated voltage
2	Built in motor protector	12	Rated current
3	Serial number	13	Rated output power
4	Model	14	Insulation class
5	Frequency	15	Max. liquid temperature
6	Max. total head	16	Weight without cable
7	Min. total head	17	Speed of rotation
8	Max. flow rate	18	IP degree of protection
9	Discharge bore	19	Max. immersion depth
10	Phase	20	Direction of rotation

### Example of nameplate for LSP

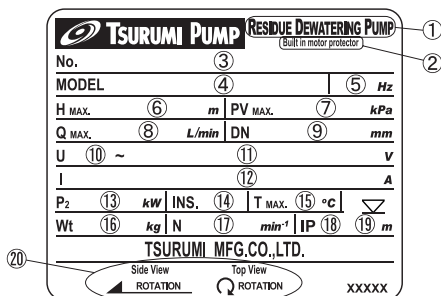

1	Residue dewatering pump	10	Phase
2	Built in motor protector	11	Rated voltage
3	Serial number	12	Rated current
4	Model	13	Rated output power
5	Frequency	14	Insulation class
6	Max. total head	15	Max. liquid temperature
7	Max. vacuum (negative pressure)	16	Weight without cable
		17	Speed of rotation
8	Max. flow rate	18	IP degree of protection
9	Suction bore	19	Max. immersion depth
	x Discharge bore	20	Direction of rotation

## Accessory Check

Verify that all accessory items are included in the package.

### LSC Type

- Hose Band ..... 1 pc
- ø25mm Hose Coupling with Union Hose Band ..... 1 set } Models for US are excluded
- Operation Manual ..... 1

### LSP Type

- ø25mm Hose Coupling with Union Hose Band ..... 1 set
- Suction Hose with Union (5m) ..... 1 set
- Suction Attachment ..... 1 set
- Operation Manual ..... 1

**Note:** If there is any problem with the product as shipped, contact your nearest dealer or Tsurumi representative at once.

## Product Specifications

**CAUTION** Do not operate this product under any conditions other than those for which it is specified. Failure to observe this precaution can lead to electrical shock, electrical leakage, fire, water leakage or other problems.

### Major Standard Specifications

Fluid	Property	Cleaning Water, Water on floor Puddles (LSC1.4S). Residual water, Puddles (LSP1.4S) ; 0 ~ 40°C
Pump	Impeller	Semi-Vortex Type
	Shaft Seal	Double Mechanical Seal
	Bearing	Shielded Ball Bearing
Motor	Specifications	Dry Type Submersible Induction Motor (2-Pole)
	Insulation	Class E
	Protection System (built-in)	Miniature Protector
	Lubricant	Turbine Oil ISO VG32 (non-additive)
Discharge Connection		Hose Coupling

### Standard Specifications (50/60 Hz)

Model	Bore (mm)	Phase	Starting Method	Output kW (HP)	Max. Head m(ft.)	Max. Capacity L/min(GPM)	Weight kg (lbs.)
LSC1.4S	25	Single	Capacitor Run	0.48 (2/3)	11/12(36/39)	—	12.0 (26.5)
LSCE1.4S	25	Single	Capacitor Run	0.48 (2/3)	11/12(36/39)	—	12.6 (27.8)
LSP1.4S	25	Single	Capacitor Run	0.48 (2/3)	6.9/7.8(22.6/25.6)	50/55(13.2/14.5)	16.5 (36.4)

**Note:** The mass (weight) given above is the dry weight of the pump itself, not including the cable.

## 4 INSTALLATION

**CAUTION**

- Do not use the pump in liquids other than plain water, such as oil, salt water, or organic solvents.
- Use with a power supply voltage within  $\pm 5\%$  of the rated voltage.
- Do not use in the water temperatures outside the range of 0 ~ 40°C, which can lead to failure, electrical leakage or shock.
- Do not use in the vicinity of explosive or flammable materials.
- Use only in fully assembled state.

**Note:** Consult your local dealer or Tsurumi representative before using with any liquids other than those indicated in this document.

### Maximum allowable water pressure

**CAUTION** Do not use at greater than the water pressure shown below.

Maximum allowable water pressure : 0.2MPa (2kgf/cm<sup>2</sup>) - discharge pressure during use

### Preparation for Installation

Before installing the pump at a work site, you will need to have the following tools and instruments ready.

- AC voltmeter
- AC ammeter (clamp-on type)
- Bolt and nut tighteners
- Power supply connection tools (screwdriver or box wrench)

**Note:** Please read also the instructions that come with each of the test instruments.

- (2) Avoid dropping the pump or other strong impact. Lift the pump by holding it firmly with the hands or by attaching a rope or chain to the handle.

 **CAUTION** The rope for suspending the pump during its installation must be of a thickness that accommodates the weight of the pump. When using a chain, make sure that the chain does not become twisted. Failure to observe these precautions could cause the rope or chain to break and the pump to fall and break, which could lead to personal injury.

**Note:** *On cable handling, see at electrical Wiring.*

 **CAUTION** Operating the pump when the inlet is blocked with debris will result in excessive noise and vibration, which can cause the pump to malfunction, leading to electrical leakage and shock.

**Note:** *This pump is supplied without piping. Use it with suitable piping material.*

*When used with a hose, pay attention to the following precautions.*

*Make sure the hose has no sharp bends, which can severely limit the flow of water. In particular, sharp bends near the base may cause air pockets to form resulting in idle operation. Lessen the degree of bedding while continuing to operate the pump. The tip of the hose (discharge end) should be located higher than the water surface. If the end of the hose is submerged, water may flow back to the pump when the pump is stopped; and if the hose end is lower than the water surface, water may overflow when the pump is turned off.*

 **CAUTION** If large quantities of earth are sucked up, damage resulting from abrasion in the pump can lead to electrical leakage and shock.

- (3) Use the pump in the upright position and on a flat surface. If the pump is likely to suck up sand or debris, mount it in a protective box or enclose it with a screen.

**Note:** *In the case of the LSP, installing the pump on an incline will alter the available circulation water capacity, lowering pump performance or even resulting in a total loss of suction.*

## Operation Water Level (LSCE1.4S)

### Start of the pump

The pump starts when the current continuously flows between the two electrodes for more than one(1) second.

**Note:** *The electrode may not detect the watersurface under conditions such as purified water or distilled water which the current does not flow cause of high specific resistance.*

**Note:** *The necessary water level to operate the pump is 85 mm from the bottom of a pump.  
In case of start by racing during the trial operation, please short-circuit for more than one (1) second with exciting items (screw driver etc.) between the electrodes, and start forcibly.  
Please keep away from those that may clog in a pump. (wire, nail, cord, etc.)*

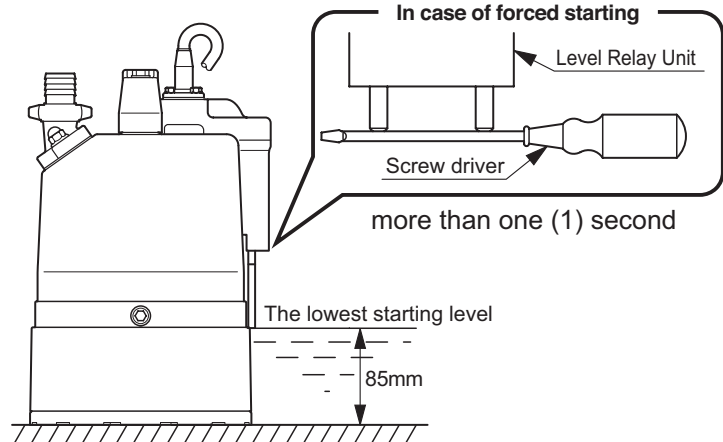

### Trial Operation

**WARNING** Never start the pump while it is suspended, as the pump may jerk and cause a serious accident involving injury.

(1) Operate the pump 3 to 10 minutes to verify the conditions listed below.

**CAUTION** If large quantities of earth are sucked up, damage resulting from abrasion in the pump can lead to electrical leakage and shock.

(2) Proceed with the normal operation if no abnormal conditions are found during the trial operation.

## Operation Water Level (LSCE1.4S)

To enable the user to bring the pumps ability into full play, this chart describes the various control modes that are made possible by the combinations of the electrode and timer functions.

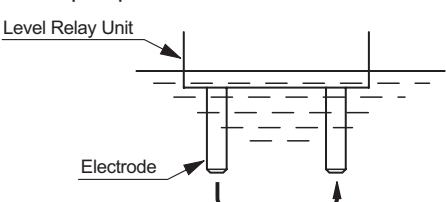
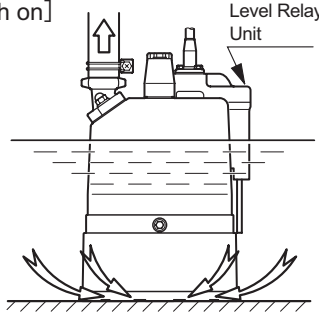
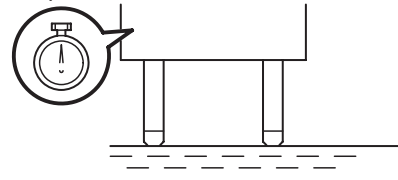
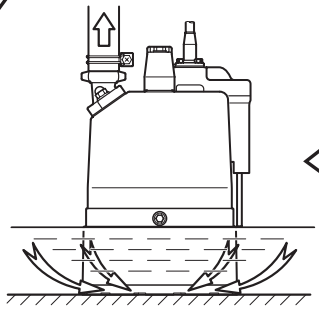
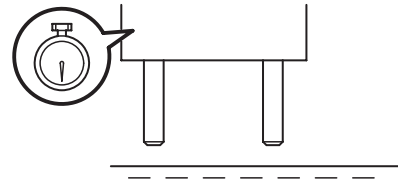
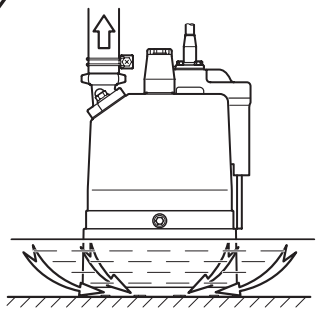
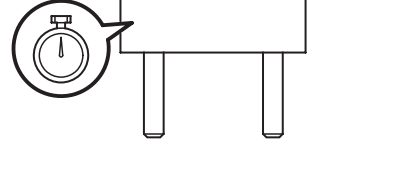
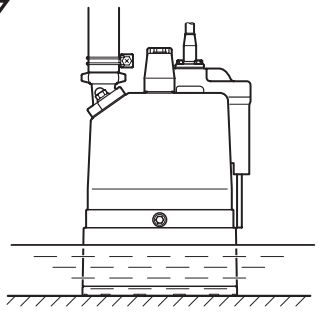
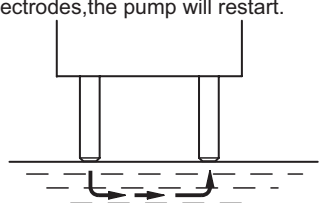
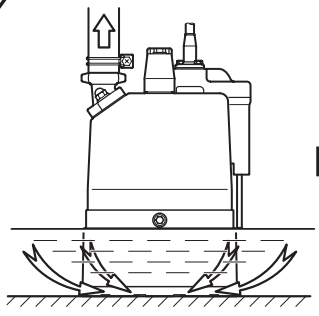
Level Relay Unit	Pump	Water Level	Condition
<p>The electrodes of the level relay unit are submerged, causing the current to operate the pump.</p>  <p>(Detection Time : more than one (1) second)</p>	Start Operation (Drainage)	Drop	<p>[Swich on]</p> 
<p>As the water level drops and the water surface recedes from the electrodes, the timer trips to drain water.</p>  <p>(Electrodes open Trips the timer)</p>	Operation (Drainage)	Drop	
<p>The draining of water by the timer lasts approximatere 1 minute.</p> <p>※If the water surface comes in contact for more than one (1) second with the electrodes witin 1 minute, the pump will operate continuously even though the timer has tripped.</p> 	Operation (Drainage)	Drop	
<p>The pump will stop 1 minute later.</p>  <p>※The pump will also stop after a continuous dry run, in some cases.</p>	Stop	Rise	
<p>When the water level rises and the water surface comes in contact for more than one (1) second with the electrodes, the pump will restart.</p>  <p>(Detection Time : more than one (1) second)</p>	Start Operation (Drainage)	Drop	

## 6 OPERATION

### Before starting

- (1) Make sure once again that the product is of the correct voltage and frequency rating.

**CAUTION** Using the product at other than rated voltage and frequency will not only lower its performance but may damage the product.

**Note:** Confirm the rated voltage and frequency on the model name plate.

- (2) Confirm the wiring, supply voltage, circuit breaker capacity, and motor insulation resistance.

■ Reference insulation resistance = 20MΩ or greater.

**Note:** The reference insulation resistance (20MΩ or greater) is the value when the pump is new or has been repaired. For the reference value after installation, see below at Maintenance and Inspection (p. 11).

- (3) The setting on the circuit breaker or other overload protector should be made in accord with the rated current of the pump.

**Note:** See the model name plate on the pump for its rated current.

- (4) When powering the pump with a generator, do not share the generator with other equipment.

### Test Operation

**WARNING** Never Operate the pump while it is suspended in the air. The recoil may result in injury or other major accident.  
Never start the pump when people are standing next to it. An electrical leak can result in electrical shock.

- (1) •Model LSC

The Pump will not start until the pump casing is wet. When doing a test operation or if it is desired to start the pump when the remaining water level is low, pour in clean water from the hose coupling. Approximately 2.5 liter of priming water is required.

- Model LSP

Remove the priming plug at the top of the pump and pour in clean water right up to the top: then replace the priming plug and tighten it. Approximately 1.8 liter of priming water is required.

- (2) Run the pump for a short time (3 to 10 minutes) and check its operation.

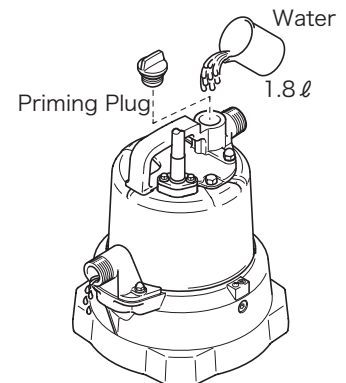

**CAUTION** Do not run the pump dry or with shut off condition. This condition may damage the pump or cause it to malfunction and may result in electrical leakage or electrical shock.

**CAUTION** In case of very excessive vibration, unusual noise or odor, turn off the power immediately and consult with your nearest dealer or Tsurumi representative. Continuing to operate the pump under abnormal conditions may result in electrical shock, fire, or electrical leakage.

### Operation

**WARNING** The pump may become very hot during operation. Be careful not to contact the pump accidentally to avoid being burned.

Always make sure the pump is primed before starting operation.

If the motor protection system operates due to an overload or malfunction, causing the pump to stop, first investigate and remove the cause before restarting.

If LSC is used: After stopping operation, detach the hose from the discharge connector and turn the pump upside-down to remove the water inside the pump.

# 7 MAINTENANCE AND INSPECTION

Regular maintenance and inspections are a necessity for continued efficient functioning of the pump. If any abnormal conditions are noticed, refer to the section on troubleshooting (P.15) and take corrective measures immediately. It is recommended that a spare pump be kept ready in case of any problems.

## Prior to Inspecting

**WARNING** Detach the cabtyre cable from the receptacle or terminals, after making certain the power supply (circuit breaker, etc.) is turned off. Failure to follow this precaution may result in a serious accident from electrical shock or unexpected starting of the pump motor.

- (1) Washing the Pump  
Remove accumulated matter from the surface of the pump and wash it with clean water. Take special care to remove any debris from the impeller.
- (2) Inspecting the Pump Exterior  
Look for any peeling or chipped paint, and make sure the nuts and bolts are fastened tightly. Any cracks in the surface should be repaired by cleaning that area, drying it and then applying a touchup coating.

**Note:** *Touchup is not supplied. Note that some kinds of damage or looseness may require that the unit be disassembled for repairs. Please consult with your nearest dealer or Tsurumi representative.*

## Regular Inspection

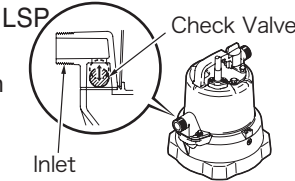
Frequency	Inspection Items
Weekly	<p>Measure insulation resistance ■Reference insulation resistance = 1MΩ minimum  <b>NOTE:</b> <i>If the insulation resistance has become notable lower than the previous inspection, an inspection of the motor will be necessary.</i></p> <p>Measure operating current. ■Compare with rated current</p> <p>Measure supply voltage ■Power supply voltage tolerance ( within ±5% of the rated voltage)</p>
Monthly	<p>Pump Inspection.            ■ A noticeable drop in performance may indicate wear in the impeller, suction cover, etc., or else clogging of the impeller, etc. Remove the clogged debris, and replace any worn parts.</p> <p>Swing check valve inspection (LSC).            ■ If the lip on the bottom plate becomes excessively rounded off, or if the rubber material of the swing check valve is deteriorated, shutoff function of the valve decrease. Replace the bottom plate and/or the swing check valve.</p> <p>Check valve inspection (LSP).            ■ The check valve may fail to operate if sand or debris at attached to it. Wash the valve and inside the inlet at regular intervals. The check valve can be removed by removing the inlet hex.bolt.</p> <p><b>NOTE:</b> <i>In some case a siphon effect when the pump stops can cause water to reverse its flow or the priming water to flow out.</i></p> 
Half-yearly	<p>Oil inspection. ■Every 1,000 hours of operation or six months, whichever comes first.</p> <p>Inspection of lifting rope or chain ■ Replace if damage, corrosion, or wear has occurred to the rope or the chain. Remove if foreign object is attaching to it.</p>
yearly	<p>Changing oil. ■Every 2,000 hours of operation or 12 months, whichever comes first.            Designated oil: Turbine Oil ISO VG32. Oil Quantity: 155ml (LSC) ; 150ml (LSP)</p> <p><b>NOTE:</b> <i>See below on OIL inspection and oil change.</i></p>
Every 2 to 5 years	<p>Change mechanical seal.  <b>NOTE:</b> <i>Specialized know-how is required for inspecting and replacing the mechanical seal. Consult with your nearest dealer or Tsurumi representative.</i></p> <p>Overhaul ■ This should be carried out even if there are no problems with the pump. The frequency depends on how continuously the pump is in use.  <b>NOTE:</b> <i>Consult with your nearest dealer or Tsurumi representative regarding overhauls.</i></p>

## 9 TROUBLESHOOTING

**⚠ WARNING** Always turn off the power before inspecting the pump. Failure to observe this precaution can result in serious accident.

Before ordering repairs, carefully read through this instruction manual, then repeat the inspection. If the problem remains, contact your nearest dealer or Tsurumi representative.

### ■ LSC

Problem	Possible cause	Countermeasure
Pump fails to start; or, starts but stops immediately (within 10 seconds).	(1) (No proper power is supplied (power outage, etc.) (2) Pump is jammed with debris, causing the motor protector to trip.	(1) Contact the electric power company or an electrical repair shop to take action. (2) Inspect the pump unit and remove the debris.
During operation, the pump stops automatically due to the tripping of the motor protector.	(1) The pump casing is filled with mud. (2) The voltage is too low. (3) The pump was operated dry for a prolonged length of time as a result of the clogging of the suction strainer of the bottom plate. It pumps too much mud. (4) A 50Hz pump is operated at 60Hz.	(1) Disassemble and clean the pump. Detach the suction cover, remove the mud, and manually turn the pump. (2) Raise the voltage to the rated voltage. (3) Remove debris. (4) Check the nameplate and replace the pump.
The pumping head and volume are small.	(1) The impeller or the suction cover is significantly worn. (2) The drain hose is kinked or clogged. (3) The suction strainer of the bottom plate is clogged. (4) The suction inlet is clogged with debris. (5) A 50Hz pump is operated at 60Hz.	(1) Repair or replace the affected part. (2) Straighten the curved or kinked part as much as possible. (3) Remove debris. (4) Remove the bottom plate to remove the debris from the inside of the suction inlet. (5) Check the nameplate and replace the pump.
Does not draw water at low water level.	(1) There is no water in the pump.	(1) Prime the pump.
After the pump stops, the priming water flows out.	(1) The swing check valve and/or the lip on the bottom plate is worn.	(1) Replace the swing check valve and/or the bottom plate.

### ■ LSP

Problem	Possible cause	Countermeasure
Pump fails to start; or, starts but stops immediately (within 10 seconds).	(1) No proper power is supplied (power outage, etc.) (2) Pump is jammed with debris, causing the motor protector to trip.	(1) Contact the electric power company or an electrical repair shop to take action. (2) Inspect the pump unit and remove the debris.
Pump operates but does not draw water.	(1) There is no priming water or is insufficient. (2) The bottom plate is installed incorrectly. (3) The suction hose or the sweeper suction attachment is not securely connected.	(1) Pour fresh water (approximately 1.8L). (2) Re-install the bottom plate with its arrow facing the suction inlet. (3) Connect it securely.
The pump stops after operating for a predetermined length of time.	(1) The voltage is too low. (2) A 50Hz pump is operated at 60Hz.	(1) Raise the voltage to the rated voltage. (2) Check the nameplate and replace the pump.
The pumping head and volume are small. Its suction performance is poor.	(1) The impeller or the suction cover is significantly worn. (2) The drain hose is kinked or clogged. (3) The suction hose or the sweeper suction attachment is clogged or submerged in sand. (4) The suction inlet is clogged with debris. (5) A 50Hz pump is operated at 60Hz.	(1) Repair or replace the affected part. (2) Straighten the curved or kinked part as much as possible. (3) Clean the suction hose and the suction attachment. (4) Remove the suction inlet to clean the suction inlet and the check valve. (5) Check the nameplate and replace the pump.
Pump vibrates or makes abnormal sounds.	(1) The motor bearings are damaged.	(1) Replace the bearings.
After the pump stops, the priming water flows out.	(1) The check valve does not function properly because it is stuck with mud.	(1) Clean the check valve and the inside of the suction inlet.

- Switch)
- Three Year Limited Warranty

# Specifications

**Our specification are guaranteed minimum!**

## Product Data

Discharge Size	3/4" - 2" NPT
Maximum Output	25 GMP
Maximum Discharge Head	36 ft.
Voltage	110
Rated Current	6.4 Amp
Motor Output	1/2 HP
Cable Length	20 ft.
Package Weight	26 lbs.
Packaged Dimensions (LxWxH)	8" x 8" x 13"

## PERFORMANCE CURVES

